



CONTROL

CONTROL VALVES



RMT Controls



Control Valve Technology

Trim Solutions

RMT Linear Control Valves have the possibility of mounting a wide variety of single stage and multi-stage trims (MST).

Depending on different disposition and dimension of drilled holes on the cage, it is possible to obtain all the desired valve characteristic curves: linear, Eq%, modified linear, low noise.

With co-axial cages it is possible to manufacture multistage trims suitable to face cavitation and severe noise abatement issues.

In extremely cases when 4 stages or more are required a Disk Stack Multi-Stage Trim (DSMST) can be provided.

The DSMST is manufactured from a brazed stack of laser cut plates, the combination of these plates obliges the fluid to pass through a series of 90° turns in which the flow energy is dissipated and the DP decreasing is controlled throughout all the trim.

With dirty liquids with large particulate, in case process condition obliges to select a multi-stage trim,

a single path multi-stage trim (SPMST) shall be used. The large passages of SPMST avoid the risk of clogging.





Fugitive Emission Control

The recent legislation on fugitive emissions have obliged refineries and other chemical and process plants to respect some emission limits in order to preserve the surrounding environment.

The costs involved with failing these limits sometimes are very high.

With this premise RMT Controls has developed different packing designs that meet the criteria

of the more stringent fugitive emission legislation. Low Emission (LEM) packing meet the criteria of ISO 15848-1. it is built up by a series of pre-formed braided PTFE based or graphoil rings with two anti-extrusion terminal rings.

There is the possibility of: adding a Leak-off in order to provide the possibility of measuring the emission level adding a follower with a dual O-ring design that has undergone extensive testing up to 100.000 cycles (CC3 class of ISO 15848-1) without failure.

Dual O-ring allows very high performances with extremely volatile gas. Live Loading Low Emission packing (LLEM) can maintain the leak performance of a new valve practically during all lifeservice.

The bellows springs maintain a constant sealing force within the packing box, providing constant low leakage performance with minimal field adjustment. Linear control valves can be equipped with Bellows Seal (BS-LEM).

The bellows seal concept isolate completely the stem from the exterior environment, metallic bellows are welded to the stem providing zero leak from the valve stem, in compliance with ISO 15848-1 class A. The design include a leak-off detection port and a redundant packing box for additional safety.

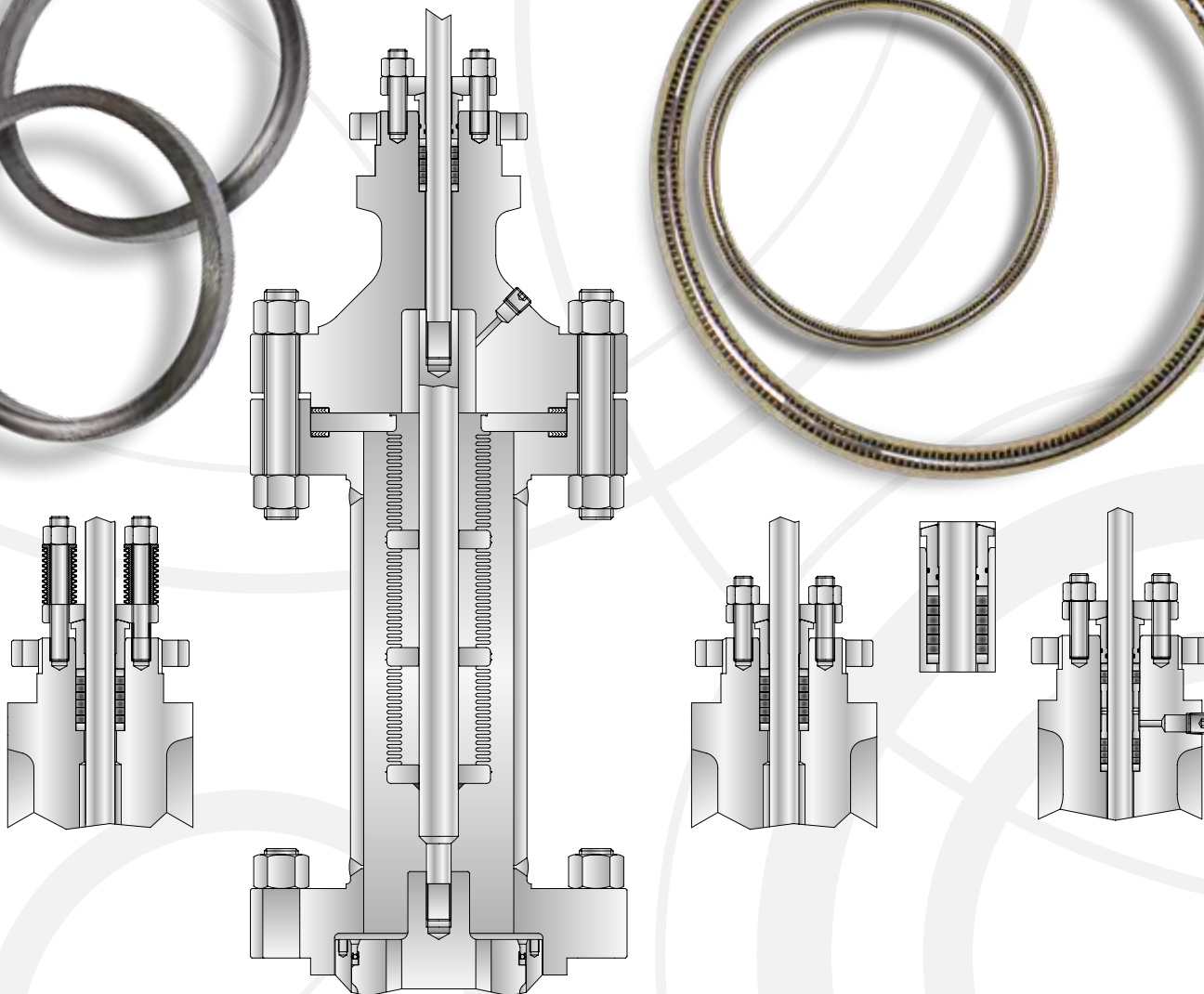



Linear Globe Control Valve 20s SERIES

22 SERIES Top Guided Globe Control Valve

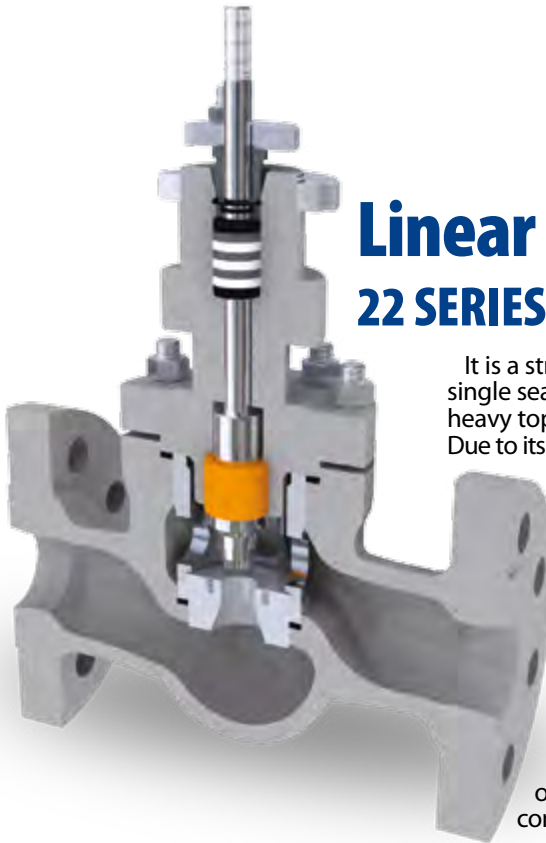

It is a straight-way, single seat, quick change heavy top guided valve. Due to its simple and rugged construction it is used in a wide range of applications.

The combination of shutoff capabilities, trim designs, precise valve positioning, and actuator stability offers optimum control performances.

Main characteristics:

- Characterized Throttling Plug:
 - Linear
 - Equal %
 - Quick-Opening
- Quick Change Design
- Heavy Top Guided
- DN up to 6"
 - Leakage Class IV by Standard, Tight Shutoff Class V and Class VI .



Many options:

- Metal/soft seat
- Packing fugitive emission compliant, bellow seal
- Exotic materials.

23 SERIES Cage Guided Globe Control Valve

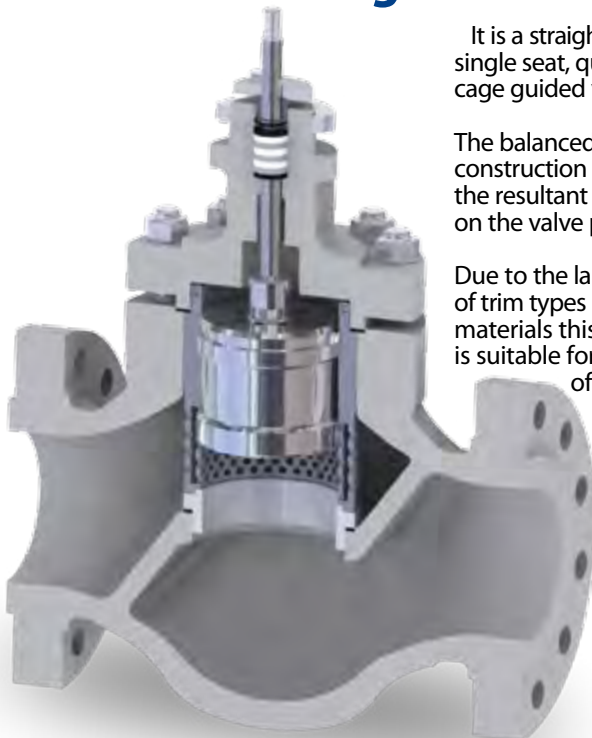

It is a straight-way, single seat, quick change cage guided valve.

The balanced trim construction reduces the resultant force acting on the valve plug.

Due to the large range of trim types and available materials this the valve is suitable for a wide range of applications with practically no limits in pressure and temperature, even heavy duties and most demanding applications.

The combination of shutoff capabilities, trim designs, precise valve positioning, and actuator stability offers optimum control performances.

Main characteristics:

- Many cage options available:
 - Linear
 - Equal %
 - Low Noise trims
 - Anticavitation Trims
 - Multi-stage Trims
- Quick Change Design
- Heavy Top Guided
- DN up to 24"
- Leakage Class IV by Standard, Tight Shutoff Class V and Class VI.



Many options:

- Metals/soft seat
- Packing fugitive emission compliant, bellow seal
- Exotic materials.

90s SERIES Angle Control Valve

They are a variation of traditional straight-line globe control valve. They are used in extremely severe services such as:

choke applications, erosive service, flashing service (in this case the flow to close configuration is preferable); or where the layout

constraints don't allow the use of a straight-line globe valve.





PRDSV Pressure Reducing & Desuperheating Steam Valve 50s SERIES:

PRDSV control valve is the most universal and compact equipment for steam conditioning. The most significant applications are turbine by-pass of conventional and combined power plants, or of cogenerating plants. Steam conditioning includes pressure reduction and desuperheating devices.

Pressure reduction area consists of a 1st stage with throttling action and variable flow area, a 2nd and eventually a 3rd stage of fixed area, which have the function of reducing noise and orienting the steam in proper direction towards the desuperheaters. The desuperheating area consists of a chamber where some spring assisted nozzles are installed and have the function of spraying water into the steam in order to reach the desired temperature.

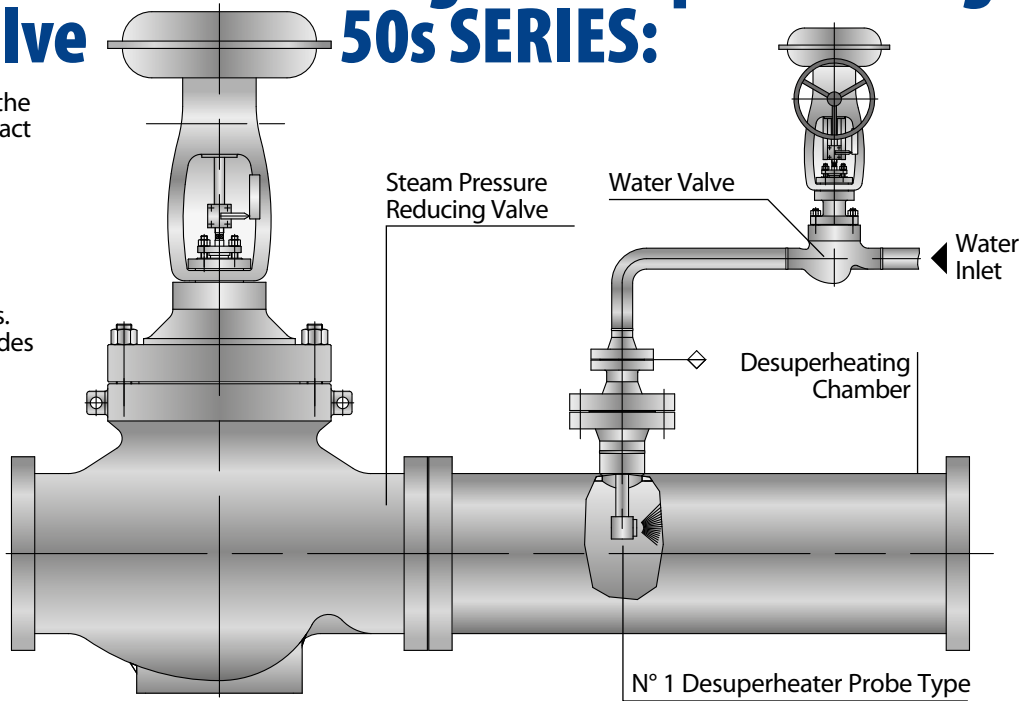

Main design features:

- High quality casted for straight line configuration or forged steel body for angle configuration. Construction with Cr-Mo steels for high temperatures as F22 and F91 grade.
- “Smooth” body contour resisting to thermal fatigue
- Split pressure class inlet/outlet and end connections adaptable to all pipe diameters
- Leakage class V, achievable with pilot assist plug. This assures no energy loss in stand-by condition
- Water injection downstream of pressure reduction area, it minimizes thermal shock and guarantees an extended valve life.

Three Way Control Valve 70s SERIES

70s Series is a line of Three-Way Globe Control Valves especially designed for heat exchangers.

Usually the process control logic analyses the input received from temperature transmitter and gives a consequent signal to the valve's positioner, in this way the valve moves

to the desired position in order to reach the temperature set-point.

The 3-Way Control Valve can be placed either upstream the heat

exchanger (diverting type) or downstream heat exchanger (mixing type).

71 Diverting Type is usually preferred when there are high T (> 100°C)

across the exchanger, in all other cases **72** mixing type is preferred due to its simpler construction and easier maintenance.

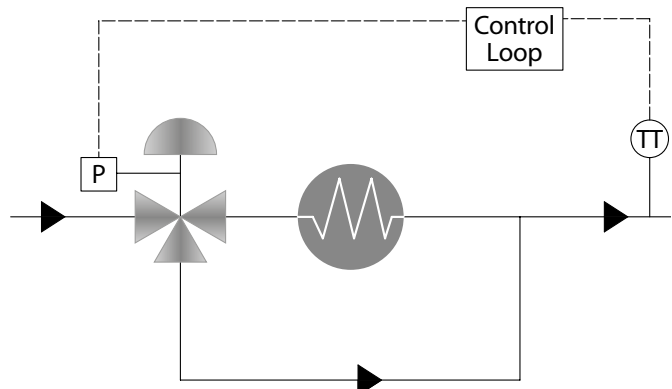
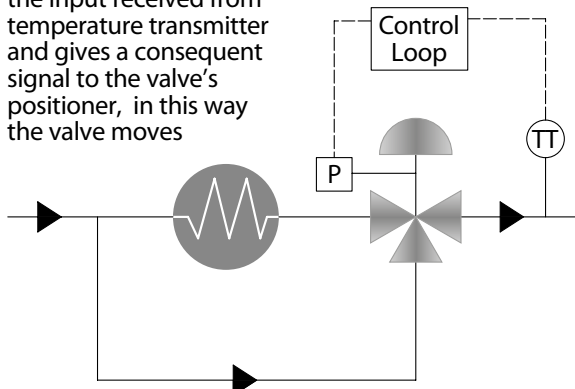



Rotary Butterfly Control Valve 10s SERIES

11 SERIES HIGH PERFORMANCE *Plain Disc*

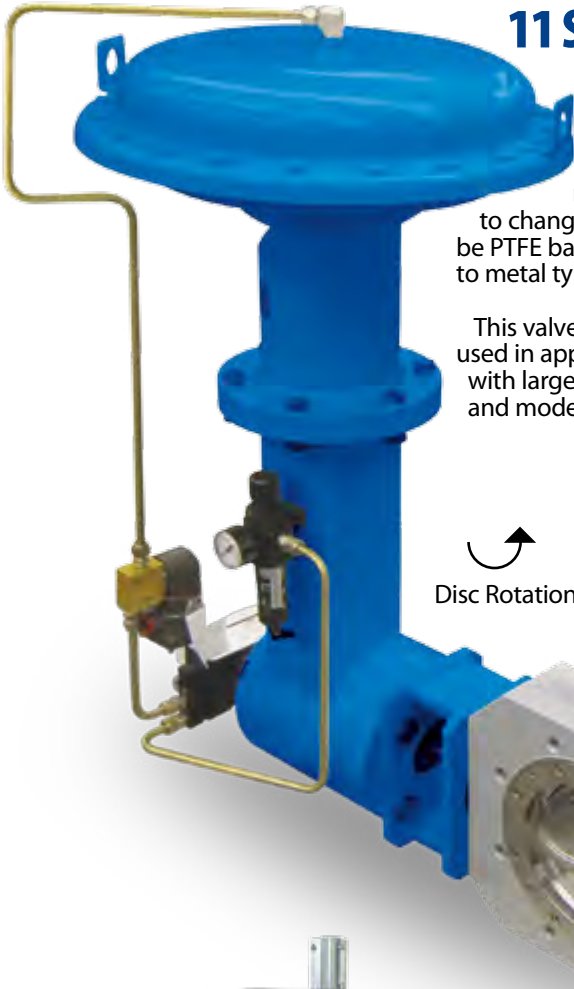

The 11 Series is provided with a double-eccentric disc, the sealing ring is very easy to change and can be PTFE based or metal to metal type.

This valve is mostly used in applications with large flow rates and moderate pressure.

The double eccentric construction guarantees a reduced torque and seal wear by minimizing its contact with the disc.

These features allows to have a valve with high performances, application flexibility and long service life.

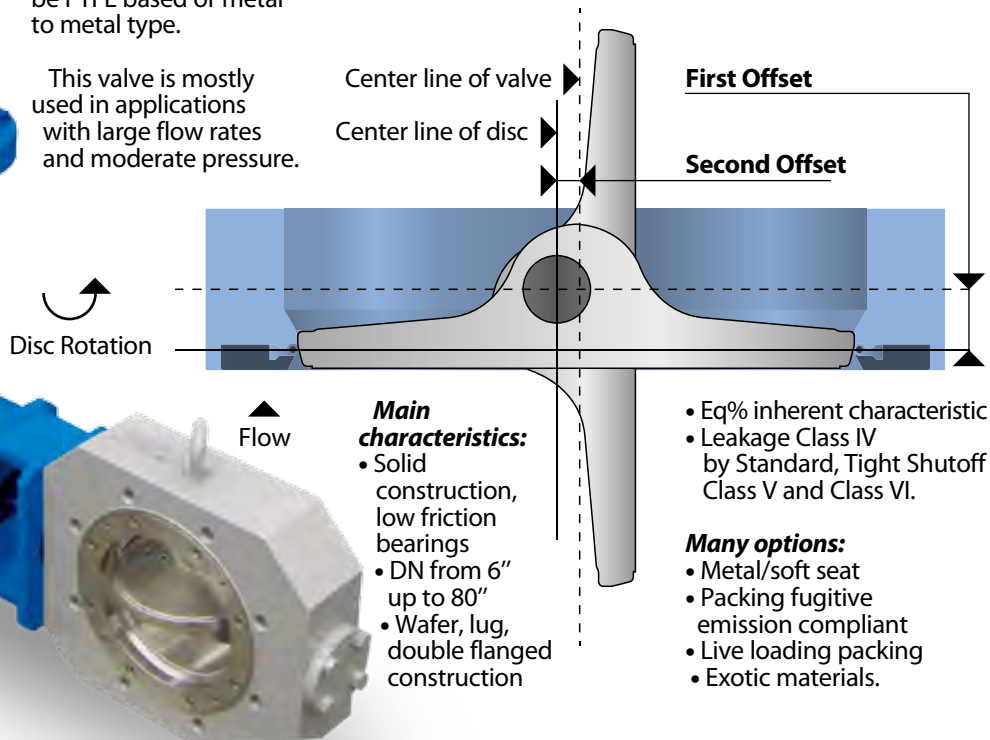

12 SERIES HIGH PERFORMANCE *Wing Disc*



The 12 Series derives from the 11 Series by modifying the disc design with special wings which increase the recovery factor and the cavitation index.

It has the same features of 11 Series allowing the valve to have high performances,

application flexibility and long service life, moreover due to its wings this valve can be used to control flow in cavitating services on liquids and for low noise control on gas with high delta P.

For very critical services the wings can be extended up to 90°.

Main characteristics:

- Solid construction, low friction bearings
- DN from 6" up to 56"

Many options:

- Wafer, lug, double flanged construction
- Eq% inherent characteristic
- Leakage Class IV by Standard, Tight Shutoff Class V and Class VI.

Main options:

- Metal/soft seat
- Packing fugitive emission compliant
- Live loading packing
- Exotic materials.



Rotary Ball Control Valve 40s SERIES

42 SERIES *Downstream Drilled Spherical Cage*



The Downstream drilled spherical cage can be used with: Liquids to help eliminate or reduce cavitation Gas to reduce noise and associated vibrations.

The valve is proposed with forged split body, side entry trunnion mounted design, it can meet the criteria of API 6D, and it is available with self-relieving or double piston effect seats.



43 SERIES *MS (Multi Stage) Control Ball Valve*

Parallel perforated plates in the ball flow opening smoothen the pressure drop as the flow passes through, this gradual pressure reductions helps in avoiding cavitation or noise problems.

conditions the internal perforated plates gives to this valve the capability to provide improved performance for demanding applications.

with ASME B16.10 face to face dimension short (standard) or long pattern, and it is available with single, double or double block-and-bleed seat options.

The possibility of customizing on the particular process

The valve is proposed with casted (standard) or forged split body,

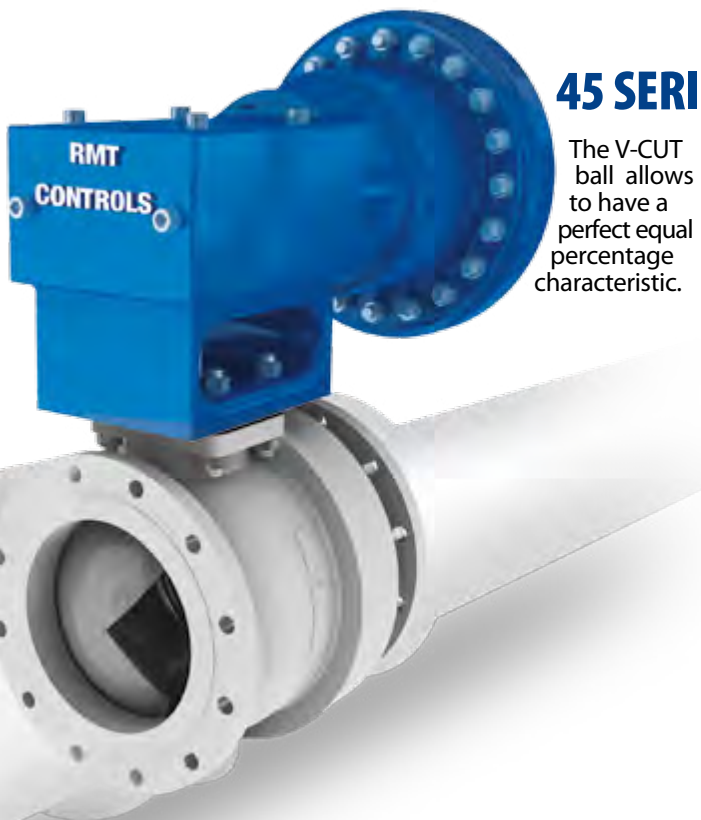

45 SERIES *V-CUT® Control Ball Valve*

The V-CUT ball allows to have a perfect equal percentage characteristic.

The V-CUT shape assures a high rangeability up to 150:1 which ensures the controllability of high turndown processes, once fully open it guarantees very high maximum Cv, with an intrinsically self cleaning and non-clogging design.

The valve is proposed in compact design with casted body, ASME B16.10 short pattern and one single seat.

Forged construction, double seat meeting API 6D criteria is also available.

Main characteristics:

- DN up to 40"
- Leakage Class V by Standard, Tight Shutoff Class VI on request.

Many options:

- Metal/soft seat
- Packing: live loading, fugitive emission compliant
- Live loading packing
- Exotic materials.

Applications

The knowledge of the process and of the type of service are fundamentals

for the right selection of a control valve, a right selection allows user yo have

a better performance in process control.

This is the reason why

RMT Controls is more than only a control valve manufacturer.

The main fields of application of our valves are:

Oil and Gas

Control valves suitable for use in:

Upstream: onshore and offshore.

Gathering networks

Downstream:

LNG, refineries, etc.

Transportation and distribution.

Careful selection of materials, taking in account ambient condition and type of service.

Petrochemical and Refining

The high variety of our control valves range (linear, rotary, special service and severe application) and the possibility of tailor made trim solutions allow to meet the true needs of the process.

Power

The long experience of our engineers team has allowed us to propose a full range of solutions in power plants, such us:

Condensate system

- Condensate pump recirculation valve
- Deareator level control valve

Feedwater system

- Boiler feedwater startup valve
- Boiler feedwater main valve
- Boiler feedpump recirculation valve

Main steam system

- Superheat spray valve & attemperator
- Reaheat spray valve & attemperator
- HP & LP turbine bypass valve with DSH system
- Vent steam

Heater Drain system

- HP & LP heater normal drain valve
- HP & LP heater emergency drain valve.

Water Treatment and Distribution

- Control valves for water gathering systems
- Control valves for water treatment facilities
- Control valves for desalination plants
- Control valves for potable water.



RMT Valvomeccanica

RMT Valvomeccanica srl

Via dei Patrioti • 21058 Solbiate Olona (VA) Italy

Ph: +39 0331 375441 • Fax: +39 0331 376847

info@rmtvalvomeccanica.com

www.rmtvalvomeccanica.com